

Smart Module User Manual



Date: September 2016







1. Main discharge pole (+)
2. Fuses cover
3. Specific connector (charge and communication)
4. Gas Gauge LEDs & push button
5. Status LED
6. Main discharge pole (-)

Installation & First time use

1. Install the Constant Current Power Supply (CCPS) dedicated to charge the Smart Module. Check that the voltage printed on the label corresponds to the nominal voltage of the battery, and that the mains voltage corresponds to your AC network voltage.
2. Install the Smart Module by arranging the CCPS cord so that it is accessible to connect it to the module, but not too close so that heat generated from the CCPS will not be transferred to the battery. Connect the CCPS to the Smart Module. Connect the CCPS to the mains. The Smart Module status LED will be orange.
3. Charge the battery until a green fixed status LED is displayed. It may take longer than 48h for the first complete charge.
4. Unplug the CCPS from the mains and unplug the Smart Module. Check the LEDs shown by the Smart Module. When pushing the button the 5 Gas Gauge LEDs should light up in red.
5. Connect the main poles of the Smart Module to your application (draining less than the 40A maximum current available for the Smart Module) The battery should provide the required current to the application.

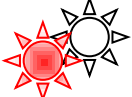

Charging the battery:

When charging the battery, the charge status is indicated by the status LED:

<p>Orange</p> 	<p>Initialization phase / Fast charge:</p> <ul style="list-style-type: none"> ➤ First check that the voltage > 0.8V/cell and the temperature within [-10°C;+40°C] ➤ If temperature > 50°C , charge duration will be longer ➤ The fast charge duration varies with the state of charge of the battery
<p>Orange Green</p> 	<p>Balancing charge</p> <ul style="list-style-type: none"> ➤ Battery already operational; more than 95% of capacity charged. ➤ Current is reduced to perform the balancing of all the cells within the battery, depending on their measured status
<p>Green</p> 	<p>Trickle charge</p> <ul style="list-style-type: none"> ➤ Balancing has been completed, battery will provide its full capacity ➤ Battery should be left this way until next use to maintain it fully charged
<p>Flashing red</p> 	<p>Defect, no charge</p> <ul style="list-style-type: none"> ➤ Contact your reseller or have a look at our FAQ list (page 12) to see which maintenance actions could be realized

Using the battery:

Connect the battery discharge cables to the main discharge poles (1 & 6 as indicated on the front cover photograph of this manual). Switch on the appliance and use until the battery is fully discharged. Depending on the current drained in the battery, the status LED indicates the following:

<p>Green</p> 	<p>Discharge</p> <ul style="list-style-type: none"> ➤ If the discharge current is higher than 100 mA, the gas gauge LEDs light up ➤ When the PreAlarm signal on Specific connector is ON, the battery is close to the end of discharge
<p>Orange</p> 	<p>Regenerative charge</p> <ul style="list-style-type: none"> ➤ Battery receives a charge current higher than 100 mA ➤ When the PreAlarm signal on Specific connector is ON, the battery is close to regenerative charge limit (*) ➤ When the regenerative charge is not allowed, the battery switches to Charge mode and may pulse the incoming current
<p>OFF</p> 	<p>Standby, battery disconnected</p> <ul style="list-style-type: none"> ➤ No voltage on main discharge poles

(*): only when the regenerative alarm option is selected For some configurations, the battery can accept a regenerative charge. This function allows recovering energy from a motor or a reversible device powered by the Smart Module.

It is recommended to start to use the battery when the battery temperature is in the -10°C to +40°C range.

It is possible to start the discharge from -20°C to +60°C occasionally. However the service life will be reduced by using the battery at high temperatures.

If the Smart Module temperature reaches 65°C, the discharge is stopped by the control system to protect the battery. In this case the status LED will turn off and the gas gauge indicator will still indicate the real battery state of charge when pushing the button. The battery is not empty and will be able to discharge again after cooling down below 55°C.

The battery goes in sleep mode after a long rest.

To wake up the battery:

- Press the push button
- OR connect a charger
- OR use the Key signal on the Specific connector

Specific connector:

The 8-pin Specific connector (charge and communication) is connected this way:

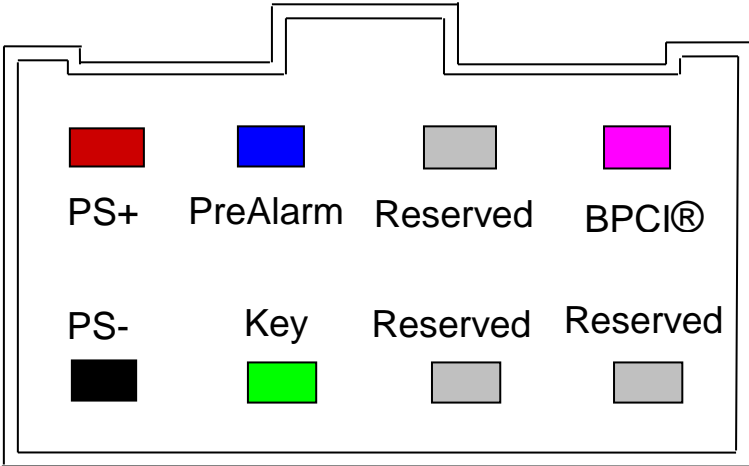

To connect to the Specific connector, use the mating connector reference: HIROSE 547-0085-8-MDF6-8DP-3.5DSA

Defect mode:

In case of defect, the electronics immediately disconnects the battery (main poles and charge pins on Specific charge and communication connector) and displays a defect signal on the status LED for one minute.

If the defect disappears, the Smart Module can be restarted by pushing the gas gauge button.

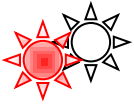
<p>Flashing red</p> 	<p>Defect, battery disconnected</p> <ul style="list-style-type: none">➤ Defect detected➤ Contact your reseller or have a look at our FAQ list (page 12) to see which maintenance actions could be realized
--	--

Storage recommendations:





























It is recommended to always store the battery connected to the charger that will maintain a trickle charge.

In case the battery cannot be connected to the charger during storage, the battery should be stored disconnected from the appliance and in a dry and cool location. Typically, a fully charged battery can be stored 6 months in a temperature range between 25°C and 35°C and a relative humidity of 65%.

Gas gauge:

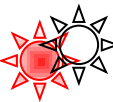
To check the available capacity left in the battery, press the push button.

The 5-level display corresponds to the following state of charge:

Battery state of charge	Status LED 0%-10%	Status LED 10%-30%	Status LED 30%-50%	Status LED 50%-80%	Status LED 80%-100%
$\leq 100\%$ > 80%					
$\leq 80\%$ > 50%					
$\leq 50\%$ > 30%					
$\leq 30\%$ > 10%					
$\leq 10\%$ > 0%					
Battery Empty					

During use, to keep the accuracy of the gas gauge, it is necessary to regularly fully discharge the battery according to the following procedure (calibration cycle):

- First, fully charge the batteries until status LED becomes green.
- Then, fully discharge until it is stopped by the battery.

If the decrease in capacity is more than 5%, it will be necessary to do several calibration cycles.

State of health:

The Smart Module includes a state of health (SOH) indicator that calculates the battery ageing and allows anticipating the end of life.

To check the state of health of the battery, depress the push button for >2 seconds.

The 5-level display corresponds to the following state of health:

Battery state of health	Status LED 0%-10%	Status LED 10%-30%	Status LED 30%-50%	Status LED 50%-80%	Status LED 80%-100%
$\leq 100\%$ $> 80\%$					
$\leq 80\%$ $> 50\%$					
$\leq 50\%$ $> 30\%$					
$\leq 30\%$ $> 10\%$					
$\leq 10\%$ $> 0\%$					

We recommend replacing the battery when the state of health is below 10%.

CAUTION:

▪ NEVER

- Immerse the battery or pour water on the battery.
- Use improper CCPS to charge the battery.
- Reverse charging of the battery.
- Open battery outside of authorized network, disassemble the battery blocks or cells (be aware that alkaline electrolyte is contained inside, and electrolyte exposure can be harmful).
- Short-circuit the battery (e.g. introducing a metallic part in the connector).
- Discharge the battery outside the predefined range conditions.
- Expose the battery to high temperatures (may activate the safety protections at the cell and battery level).
- Expose the battery to fire.

▪ Warning

- If any leakage of electrolyte occurs, stop using the battery immediately. Electrolyte is corrosive to some metals.
- If electrolyte comes in contact with your skin or clothes, immediately wash with soap and water.
- If electrolyte comes in contact with your eyes, wash thoroughly with water and immediately consult a doctor.

▪ Electrical Hazards

With the typical connection on a 36V battery, the main battery poles and the charge poles can operate normally over 50 volts during charge. Bodily contact with 50-60 volts may cause a mild shock.

Batteries are capable of delivering short circuit currents of more than one hundred amperes.

- Do not wear rings, watches, bracelets, etc. when working on batteries.

Short-circuit currents through these objects can cause serious burns or injuries.

- Use only tools with insulated handles.

FAQ:

Fuses:

If the fuses are blown, it is possible to change them by removing the cover with a screwdriver and then removing the defective fuses.

Be careful to use the correct fuse as a replacement:

- For 12 V and 24 V batteries, a 32V rated ATO fuse @15A for charge and @40A(Only for VH module) for discharge is required (Use a fuse @30A for a VHT Smart Module).
- For 36 V batteries, a 58V rated fuse @15A for charge and @40A(Only for VH module) for discharge is required. (Use a fuse @30A for a VHT Smart Module)

Reset:

In case the battery seems blocked in standby mode, it is possible to reset it by making a strap between the two small holes close to the 8-pin Specific charge and communication connector with the special reset tool:



TROUBLESHOOTING:

THE BATTERY DOES NOT DELIVER CURRENT	
Possible causes	Actions
The battery is empty (pressing the “gas gauge” button results in blinking of the 0%-10% LED).	Charge the battery with the CCPS (charger).
The discharge fuse is blown.	Check and replace the blown fuse.
The “Key” command is used and is in the “OFF” position.	Switch the “Key” command in “ON” position.
The battery is in sleep mode (Status LED is OFF). The battery stayed in discharge mode with drain current lower than 100mA for a duration higher than automatic sleep time (4h).	To wake up the battery: Press the “gas gauge” button or Connect/ disconnect the CCPS or Switch the “Key” command to OFF and then to ON.
The temperature of the battery went up to +65°C. The Status LED is OFF. The battery is hot and when the “gas gauge” button is pressed, this results in lighting of the gas gauge LED.	Wait for the battery to cool down. The battery will discharge again once the temperature goes down to +55°C. At that time, the status LED will light up.
The Status LED is blinking red. The battery is in defect mode.	Press the gas gauge button. If the battery stays in defect mode, return the battery to the after sales service.
Others	Return the battery to the after sales service.

THE BATTERY DOES NOT CHARGE	
Possible causes	Actions
The charge fuse is blown.	Check and replace the blown fuse.
The temperature of the battery is lower than -10°C or higher than +40°C. The status LED is orange. The battery was charged just after a	Put the battery in an area where the temperature is between -10°C and +40°C (0°C to +30°C recommended). The charge phase will start

discharge at high current which caused the temperature to rise above +40°C.	automatically when the temperature of the battery will be between -10°C and +40°C.
The temperature of the battery is very different from ambient temperature (typically a cold battery such as 0°C connected to a CCPS in a heated room such as 20°C). The status LED is orange.	The charge phase will start automatically when the temperature of the battery will be close to the temperature of the room (typically when the temperature difference will be lower than 10°C).
The status LED is OFF when the CCPS is connected to the battery.	Check the connectors. Check the CCPS. If the connectors and the charger are OK, return the battery to the after sales service.
The Status LED is blinking red. The battery is in defect mode.	Press the gas gauge button, if the battery stays in defect mode; return the battery to the after sales service.
Others	Return the battery to the after sales service.

THE BATTERY DOES NOT GO TO TRICKLE CHARGE (STATUS LED GREEN)	
Possible causes	Actions
The battery is brand-new. The duration of the balancing charge is set to 48 hours during the assembly process and increases automatically during a period without charge.	After several cycles of charge & discharge with extended charges, the duration of the balancing will be set to its minimum value (4~5hours). The battery can be used even if the balancing phase is not finished but the capacity of the battery will be slightly reduced (> 95% capacity).
The balancing charge duration has increased because the battery was partially charged for a few hours each day.	After several cycles of charge & discharge with extended charges, the duration of the balancing will be set to its minimum value (4~5hours). To avoid this phenomenon, avoid charging the battery partially or charge the battery for at least 12 hours.
The balancing charge duration has increased because the battery was stored for several weeks.	After several cycles of charge & discharge with extended charges, the duration of the balancing will be set to its minimum value (4~5hours). To avoid this phenomenon, leave the

	battery connected to the charger during storage.
--	--

THE BATTERY IS EMPTY BEFORE GAS GAUGE LEVEL ACTUALLY FALLS TO 0%-10% LEVEL (BLINKING RED)

Possible cause	Action
The autonomy of the battery is reduced after repeated use of the battery. This is a normal phenomenon called ageing.	To do a calibration of the gas gauge to the true capacity of the battery, do a complete charge of the battery until the status LED lights up in green. Then discharge once completely until blinking of gas gauge low level LED (0%-10%). If the shift between gas gauge capacity and cell capacity is greater than 10%, it is necessary to do several calibrations to have accurate gas gauge indication.

THE BATTERY SEEMS BLOCKED, PUSH BUTTON AND CONNECTION OF CHARGER HAVE NO EFFECT

Possible cause	Action
The calculator integrated in the battery controller is blocked. The status or gas gauge LED's are not in a normal status	Do a reset as described in the "FAQ" section (page 12).

PERSONAL NOTES



**For more information,
please consult your local
reseller**

Marketing reference: **1.011.167**

Published By ARTS Energy

Information in this document
is subject to change without
notice and becomes
contractual only after
written confirmation by ARTS Energy

ARTS Energy
10 Rue Ampère- Zone industrielle
16440 Nersac
Téléphone général : +33 (0)5 45 90 35 50
Fax général : +33 (0)5 45 90 37 65



